



# Series 4000

*– The Advanced New Range  
of Labelling Machines*

## Series 4000 Dispenser

*Heavy duty stepper motor*

*High accuracy*

*Encoder control*

*Direct function access*

*Low noise level*

*Easy to operate*

*Low maintenance costs*

*Many options*



The series 4000 consist of modern, newly designed label dispensers, using the latest technology in stepper motor and microprocessor technique.

It is designed to meet the highest requirements in speed, accuracy and ease of operation.

The powerful stepper motor operates with a repeatability of a fraction of a millimetre, at an almost silent noise level.

It has an operator friendly display panel with direct function access.

8 selectable languages are included in the system.

The advanced microprocessor control and the illuminated 2-line display give the operator an easy way to control the machine and to store all settings in the memory.

The series 4000 is available in different sizes and as right and left hand models.

It is ideal for top- side- and bottom labelling and a wide range of mounting brackets are available.

## Accessories:

Hot-foil print system, model M01, for print of date, batch number and similar. Settings for print time and heating level can be stored in the memory, linked to each specific label.

Encoder for true speed following of wrapping lines.  
Suitable in intermittent packaging machines.

Barcode reader, for controlling the readability of the barcode, printed on the label. The system will send a signal to the control unit, or to any desired external unit, if the code is not readable.

The effect can be: stop dispenser, flash a light, stop other units, or similar.

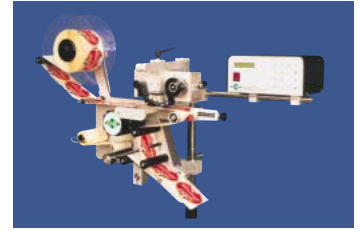

## Technical specifications:

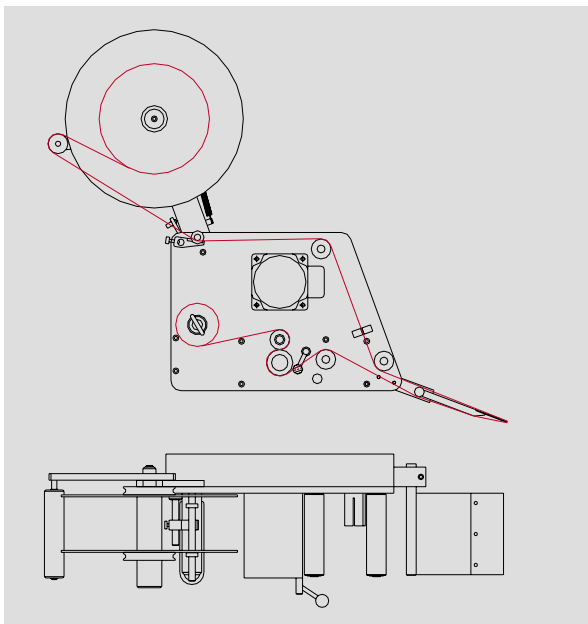

Height: 600 mm

Width: 180 mm

Length: 730 mm

### Label dimensions:

Length:  
minimum 10mm  
maximum 250mm (standard)  
option 999mm  
Width:  
minimum 10mm  
maximum 120mm (model 4-120)  
200mm (model 4-200)

### Label roll:

Diameter:  
standard max. Ø270mm  
options: Ø310/400mm  
Core: min. Ø40mm

Drive system:  
Stepper motor

Speed/capacity:  
Variable speed 0-40m/minute.  
Up to 500 labels per minute.

### Power:

230V AC 50/60 Hz. 250 watt

### Weight:

Dispenser unit (without control box), 16 kg  
Control box, 7 kg



Office: +353 (0)404 80027  
Mob: +353 (0)87 236 7502  
Web: [www.gisltd.ie](http://www.gisltd.ie)  
Email: [info@gisltd.ie](mailto:info@gisltd.ie)